



Training Manual

EUPEN Cable Inc.

Serving the World Since 1747

800.419.5100

www.eupen.us





EUPEN Cable Inc.

Serving the World Since 1747

Contents

Jumper Connectors

Standard 1/2" Connectors	1
Hiflex 1/2" Connectors	3
Hiflex 1/2" Rt. Angle Connectors	5

Feeder Connectors

Standard 5/8" Connectors	7
MonoBlock 7/8", 1-1/4" and 1-5/8" Connectors	
F-Series Tool Instructions	8
Manual Installation	10
Modular 2-1/4" Connectors	12
Cable Products Reference Sheet	14
Prep Tool/Torque Wrench Selection Guide	15
F-Series Blade & Pin Replacement Instructions	17

800.419.5100

www.eupen.us



Standard 1/2" Straight and Rt. Angle Connectors Installation Instructions



	NF, NM	NM50VL1/2	7/16M	7/16MVL1/2	7/16F	EIA
	2 x 19mm	19mm + 23mm	19mm + 24mm + 27mm	19mm + 23mm + 32mm	19mm + 24mm	2 x 10mm + 19mm + 24mm

RECOMMENDED TOOLS



CABLE PREPARATION - A + B

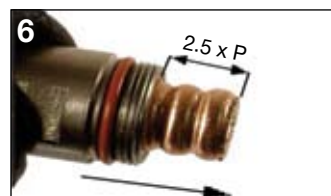
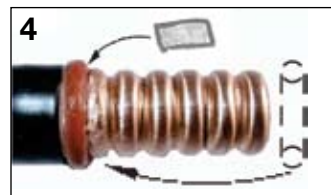
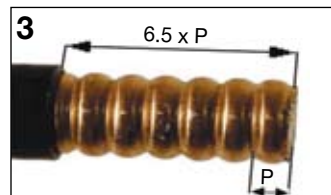
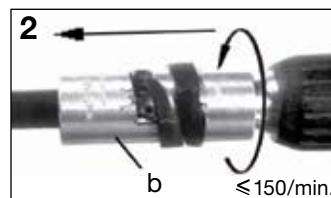
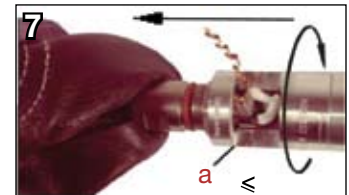

Standard 1/2" Straight and Rt. Angle Connectors Installation Instructions

(continued)

CABLE PREPARATION – B + C

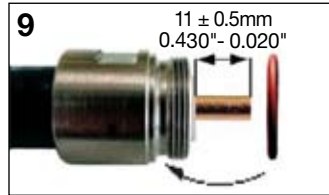
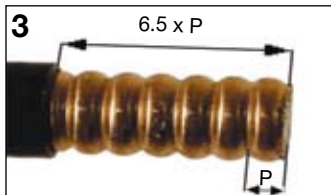

NOTICE: KABELWERK EUPEN AG AND EUPEN US disclaims any liability or responsibility for the results of improper or unsafe installation practices.

Hiflex 1/2" Straight Connectors Installation Instructions



NF NM 7/16F 7/16M

	NF, NM	7/16M	7/16F
	2 x 19mm	19mm + 24mm + 27mm	19mm + 24mm

RECOMMENDED TOOLS



CABLE PREPARATION - A + B

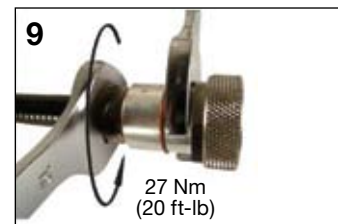
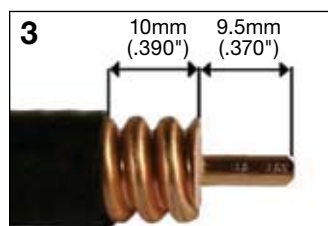
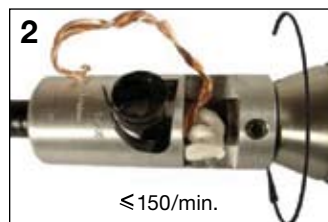
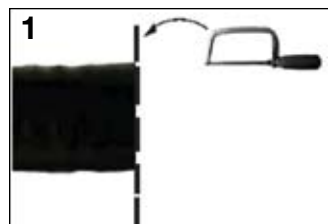

Hiflex 1/2" Straight Connectors Installation Instructions

(continued)

CABLE PREPARATION – B + C

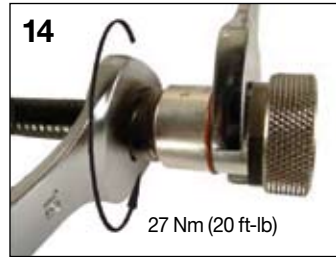
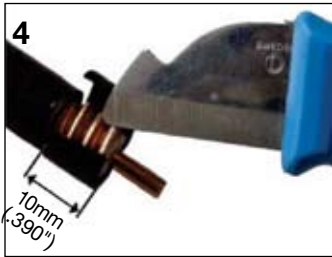
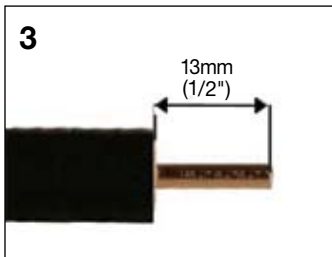
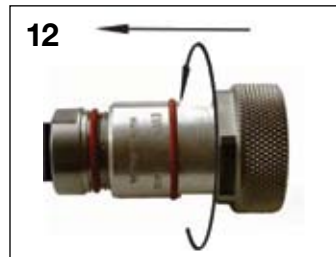
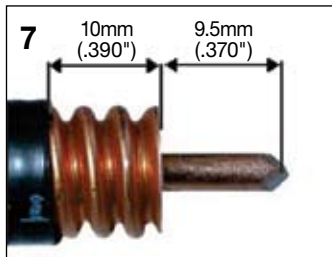
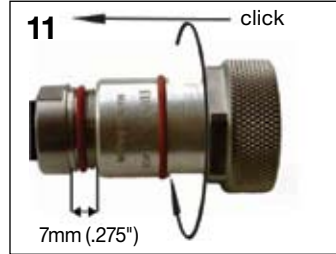
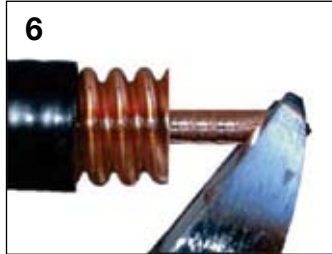
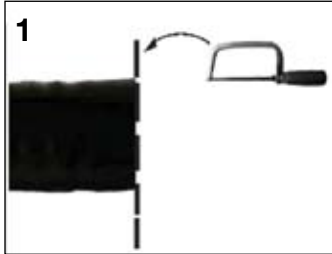

NOTICE: KABELWERK EUPEN AG AND EUPEN US disclaims any liability or responsibility for the results of improper or unsafe installation practices.



Hiflex 1/2" Rt. Angle Connectors Installation Instructions



NM

7/16M

	NM	7/16M
	2 x 19mm + 23MM	19mm + 23mm + 32mm

RECOMMENDED TOOLS

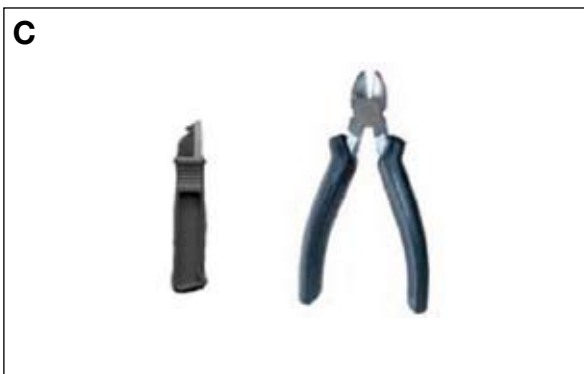

CABLE PREPARATION – A + B

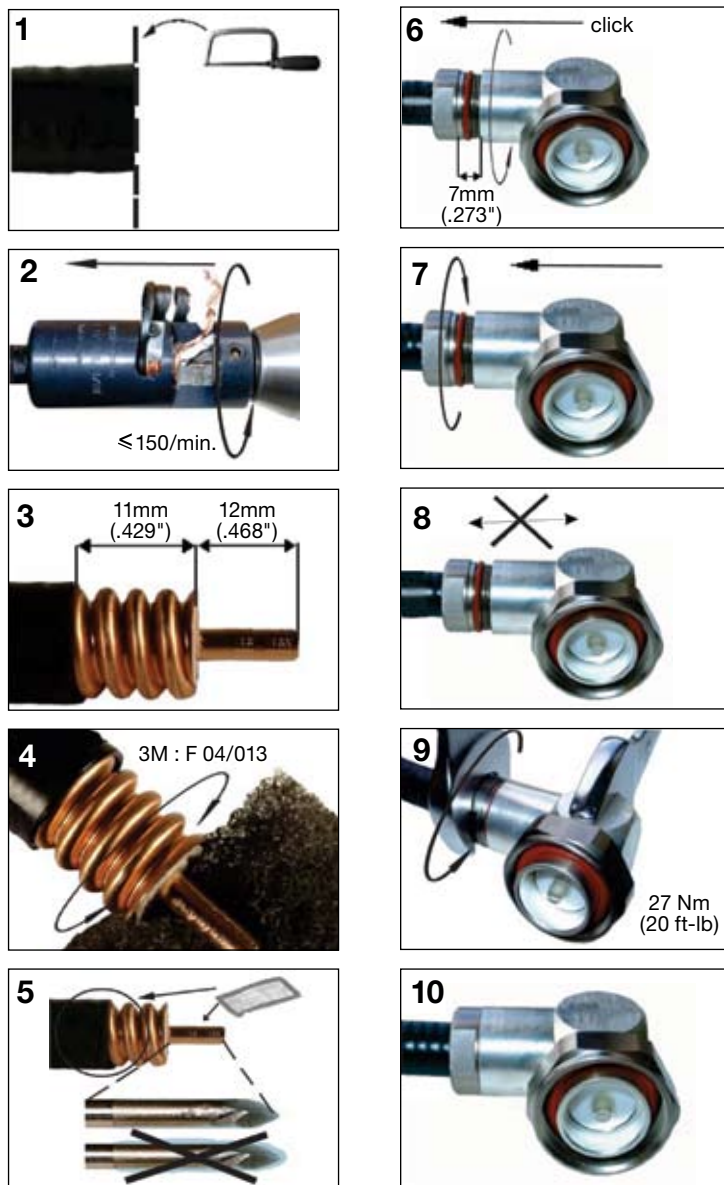

Hiflex 1/2" Rt. Angle Connectors Installation Instructions

(continued)

CABLE PREPARATION – B + C

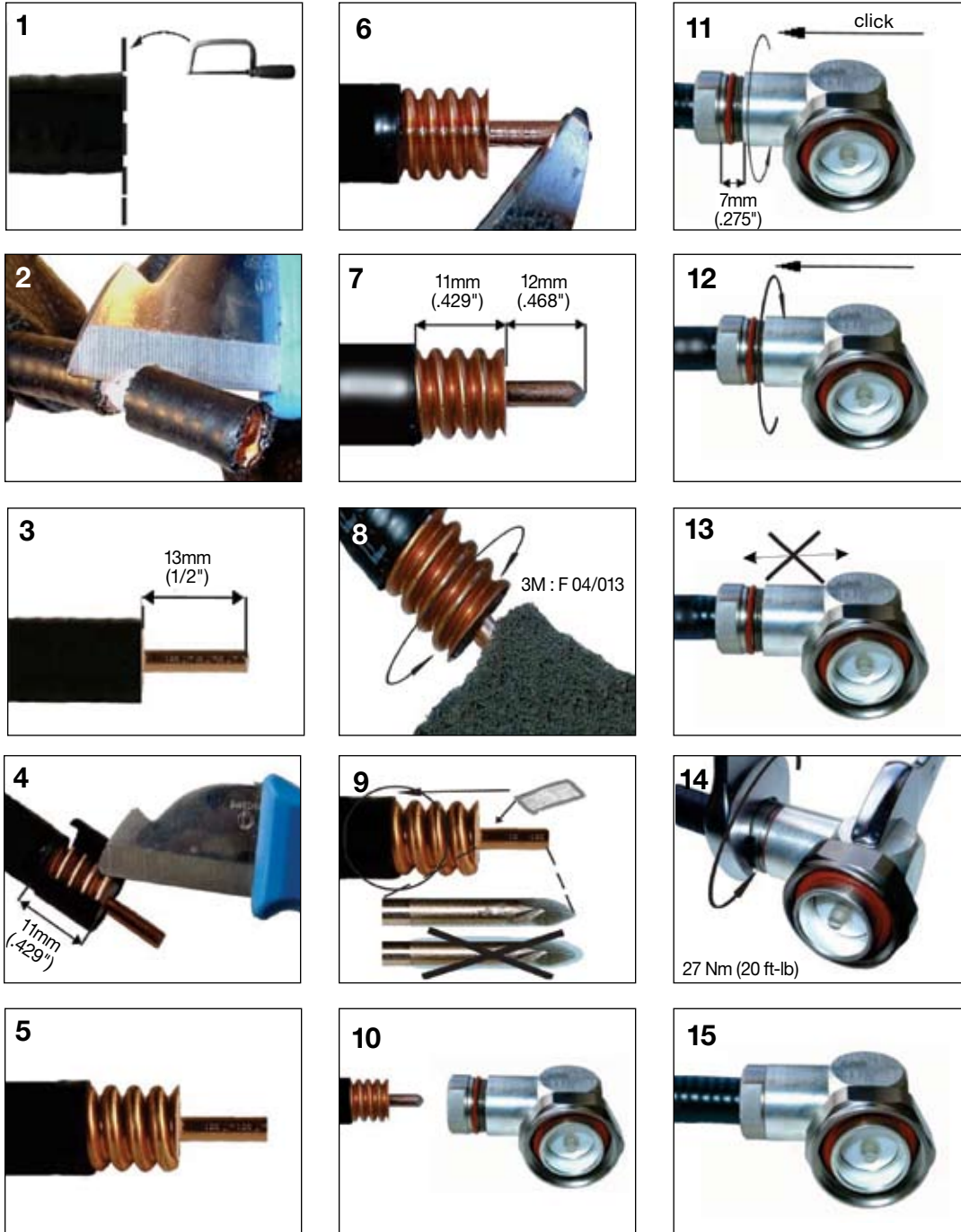

NOTICE: KABELWERK EUPEN AG AND EUPEN US disclaims any liability or responsibility for the results of improper or unsafe installation practices.

Standard 5/8" Connectors Installation Instructions

RECOMMENDED TOOLS

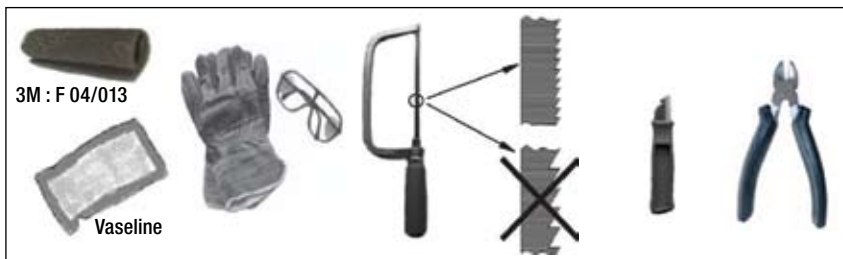

CABLE PREPARATION

- | | | | |
|-----------------|--|------------------|---|
| <p>1</p> | <p>Make a straight cut at the end of the cable. Cut and remove the jacket in the valley after the seventh complete corrugation (approx. 45mm).</p> | <p>6</p> | <p>Take out the insulator with a sharp knife.</p> |
| <p>2</p> | <p>Put the "O" ring on the cable as shown. Use silicon grease on "O" ring.</p> | <p>7</p> | <p>Cut the inner conductor 1 max 10mm.</p> |
| <p>3</p> | <p>Place the rear portion of the connector on the cable.</p> | <p>8</p> | <p>Cut the conductor 1 max 10mm.</p> |
| <p>4</p> | <p>Using the can opening method, remove the outer conductor very close to the end of cable clamp.</p> | <p>9</p> | <p>Deburr.</p> |
| <p>5</p> | <p>If you find some part of copper higher than the cable clamp end, cut it with a cutting tool.</p> | <p>10</p> | <p>Turn the rear portion of the connector while holding the connector body.</p> |

NOTICE: KABELWERK EUPEN AG AND EUPEN US disclaims any liability or responsibility for the results of improper or unsafe installation practices.

F-Series Cable Prep Tool Instructions

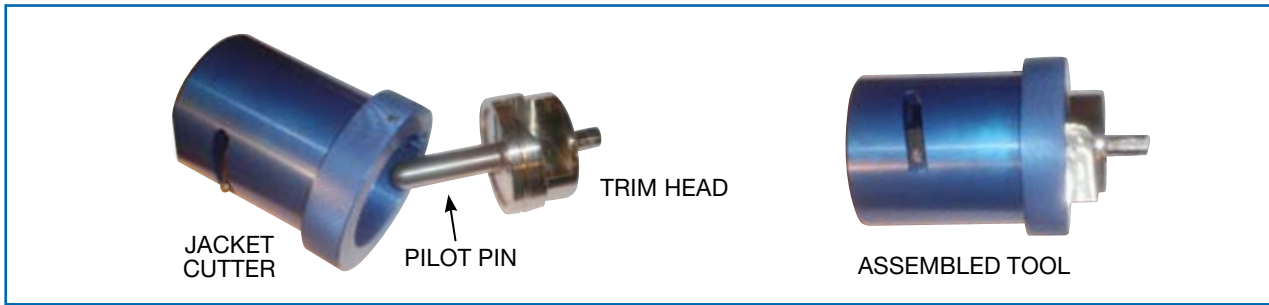

The Eupen F-Series Tool is a dual function, drill-mounted cable prep tool designed for use with Eupen MonoBlock connectors and Eupen feeder cable.

ATTENTION: Safety glasses and gloves should be worn at all times when operating drill-mounted tools. Always use tools in accordance with safety procedures and only for the intended purpose. Your safety program should include but should not be limited to standards of OSHA, NEC and NESC.

1. Begin with a STRAIGHT section of cable cut in the valley of corrugation for best results.



2. With the Jacket Cutter attached to the Trim Head, use a drill to turn the F-Series Tool onto the cable clockwise at low rpm.

LOW SPEED – CLOCKWISE



Push slightly while the jacket is being cut until the tool stops forward travel and spins freely.

3. Remove tool from cable.

Note: Outer jacket should be cut to peak of corrugation.

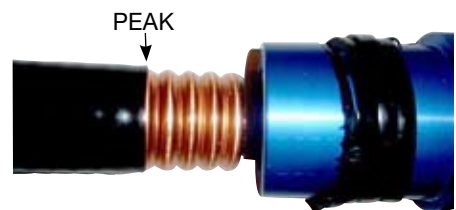

4A. Install O-ring in the valley next to the jacket cut.

4B. Install silicone rubber ball inside inner conductor. Apply grease as per connector instructions.

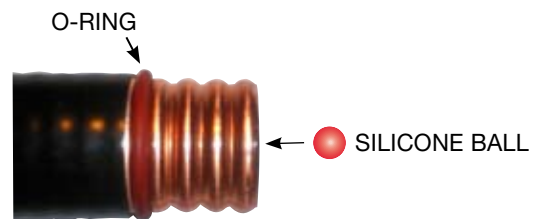

5. Install rear portion of connector over the O-ring, then pull forward so that the forward edge of the connector is covering the spring fingers and aligned over the corrugation peak.



F-Series Cable Prep Tool Instructions

(continued)

- 6.** Remove Jacket Cutter from Trim Head.
(Hold Jacket Cutter firmly. Lift locking pin and separate from Trim Head).

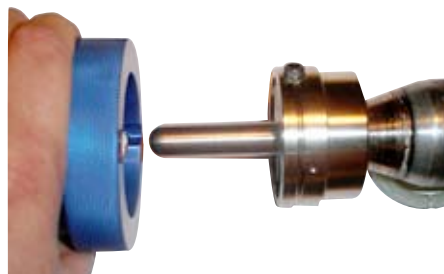

- 7.** Using drill turning clockwise on low RPM.
Cut the end of the cable with the Trim Head.

The Trim Head will spin freely and bottom out on the connector body when the cut is complete.

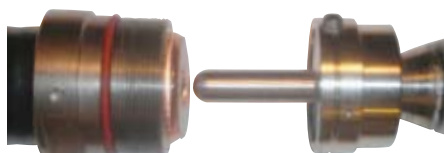

LOW SPEED – CLOCKWISE

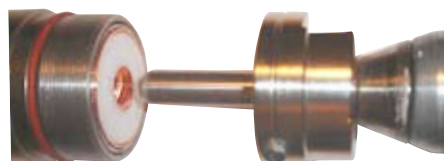
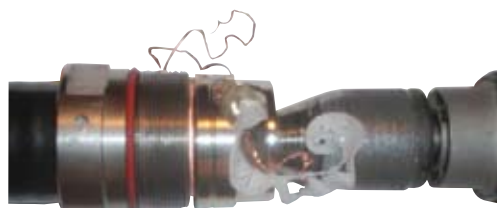

- 8.** Complete connector installation
as per connector instructions.



REPLACEMENT PARTS

	F-78	F-114	F-158
Jacket Cutter Assembly	F-78-JCA	F-114-JCA	F-158-JCA
Trim Head Assembly	F-78-THA	F-114-THA	F-158-THA
Jacket Cutter Blade	SPB09	SPB12	SPB10
Trim Head Blade	SPB14	SPB14	SPB11
Pilot Pin	SPB03PP	SPB05PP	SPB01PP

Monoblock 7/8", 1-1/4", 1-5/8" Connectors

Manual Installation Instructions



	NM	7/16M	7/8"	1-1/4"	1-5/8"
	19mm	32mm	30mm	1-11/16	2-1/4
				\varnothing 48mm	\varnothing 63mm

Please use the proper cable preparation tool below and refer to its instructions for use. Follow the manual installation process only if these tools are not available.



7/8"	F-78
1-1/4"	F-114
1-5/8"	F-158



Manual Method

-
-
-
-
-
-
-
-

(continued on back)



Monoblock 7/8", 1-1/4", 1-5/8" Connectors Manual Installation Instructions

(continued)

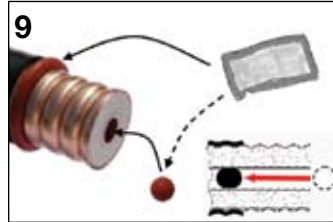





7/8" : 30 Nm (22 ft-lb)
1-1/4" : 40 Nm (29 ft-lb)
1-5/8" : 50 Nm (37 ft-lb)



NOTICE: KABELWERK EUPEN AG AND EUPEN US disclaims any liability or responsibility for the results of improper or unsafe installation practices.

Modular 2-1/4" Connectors Installation Instructions



	NM	NF	7/16M	7/16F	EIA 7/8"	2-1/4M		
	19mm 30mm	30mm	27mm 30mm	30mm	2 x 10mm 30mm	∅ 5mm	∅ 63mm	
						 2 x 2-5/8"		 HEX 3mm



Cable Preparation

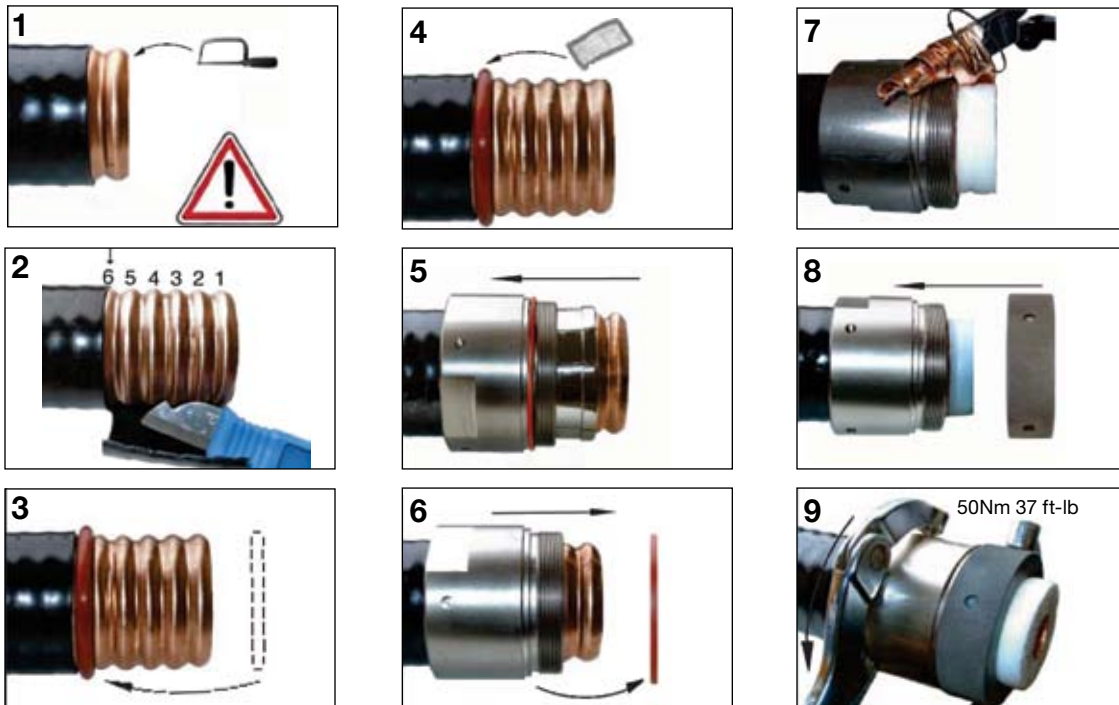

(continued on back)

Modular 2-1/4" Connectors Installation Instructions

(continued)

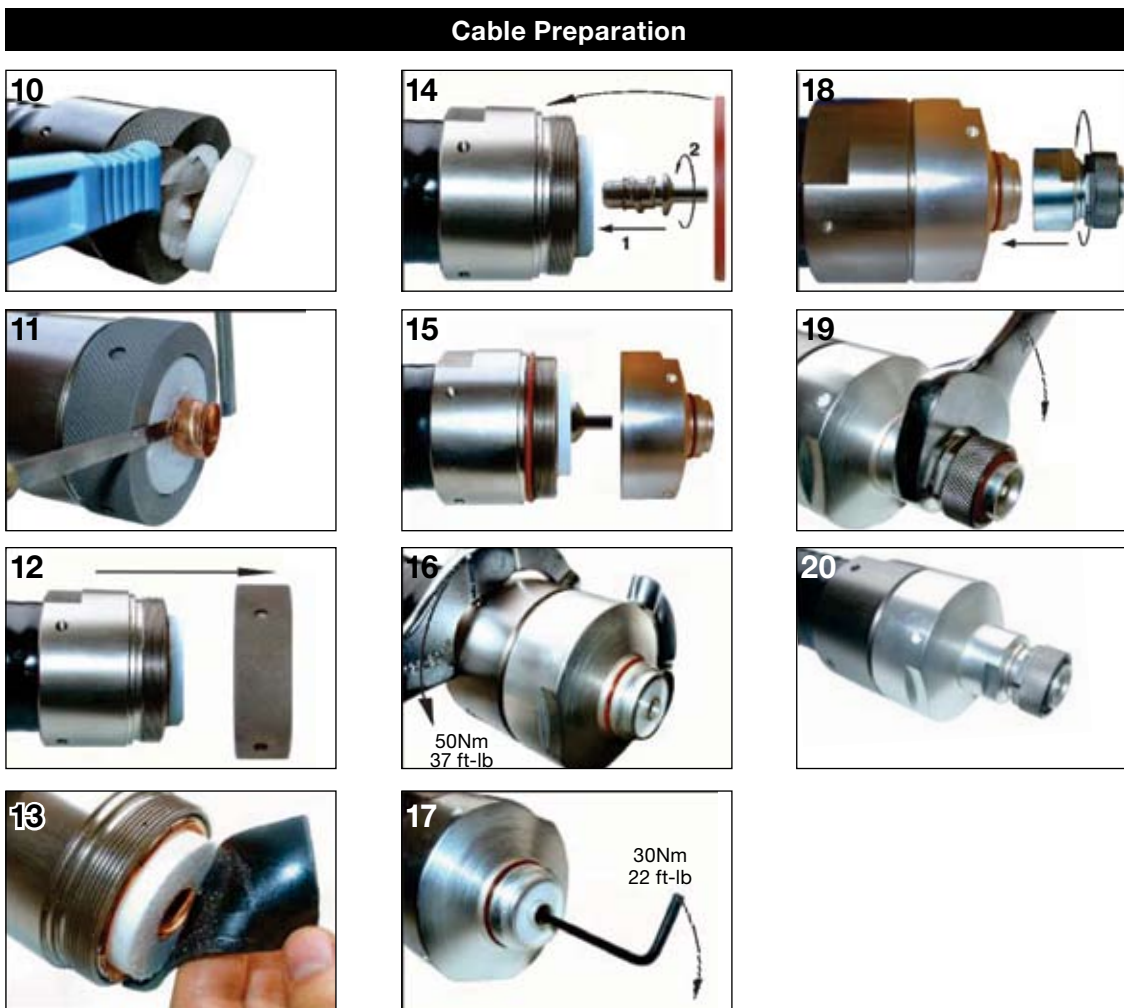



Cable Products Reference Sheet

EC4-50-HF
1/2" Hiflex



EC4-50
1/2"



EC5-50A
7/8"



EC6-50A
1 1/4"



EC7-50A
1 5/8"



EC12-50
2 1/4"

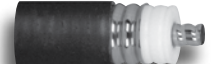

CONNECTORS

N-male
NM50B12X

N-male
NM50V12

N-male
NM50V78MA

N-male
NM50V114M

N-male
NM50V158MA

N-male
NM50V214

N-female
NF50B12X

N-female
NF50V12

N-female
NF50V78MA

N-female
NF50V114M

N-female
NF50V158MA

N-female
NF50V214

N-male Rt. Angle
NM50BL12X

N-male Rt. Angle
NM50VL12

DIN-male
7/16M50V78MA

DIN-male
7/16M50V114M

DIN-male
7/16M50V158MA

DIN-male
7/16M50V214

DIN-male
7/16M50B12X

DIN-male
7/16M50V12

DIN-female
7/16F50B12X

DIN-female
7/16F50V12

DIN-female
7/16F50V78MA

DIN-female
7/16F50V114M

DIN-female
7/16F50V158MA

DIN-female
7/16F50V214

DIN-male Rt. Angle
7/16M50BL12X

DIN-male Rt. Angle
7/16M50VL12

JUMPERS

EC4 - 100 - DMDM

CABLE

LENGTH

CONN. TYPE

EC4: 1/2" STANDARD
EC4-HF: 1/2" Hiflex

030: 1'
061: 2'
100: 3' (1m)
122: 4'
150: 5' (1.5)
183: 6'
200: 6.5' (2m)
213: 7'
250: 8' (2.5m)
274: 9'
300: 10' (3m)
366: 12'
426: 14'
488: 16'

D: 7/16 DIN
N: TYPE N
M: MALE
F: FEMALE
R: RT. ANGLE
L: LOOSE
O: OFF

CALL CUSTOMER SERVICE
FOR CUSTOM JUMPERS



Prep Tool/Torque Wrench Selection Guide

Match the cable to connector from left to right to determine the appropriate Prep Tool.

Cable Part Number	Cable Size	Connector Type	Recommended Prep Tool
EC1-50-HF	1/4" Hiflex	Hiflex	SPTC50B14X
EC4-50-HF	1/2" Hiflex	Hiflex	SPTC50B12X
		Rt. Angle Hiflex	SPTC50BL12X
EC4-50	1/2"	Standard	SPTC50AV12
		Rt. Angle Standard	
EC5-50A	7/8"	MonoBlock	F-78
EC6-50A	1 1/4"	MonoBlock	F-114
EC7-50A	1 5/8"	MonoBlock	F-158
EC12-50	2 1/4"	Two Piece	SG-5528 (or) SPB13

Connector Body Torque Specifications				
Connector Type	Wrench size	Max Wrench Head Thickness	Back Nut Torque Spec	Part Number
1/2" Hiflex	19mm	N/A	15 lb-ft	TQ-34-F15
1/2" Standard	19mm	7mm	15 lb-ft	TQ-34-F15
7/8" MonoBlock	30mm	12mm	22 lb-ft	TQ-30MM-F22
1 1/4" MonoBlock	1 11/16"	N/A	29 lb-ft	TQ-11116-F29
1 5/8" MonoBlock	2 1/4"	N/A	37 lb-ft	TQ-214-F37
2 1/4" Two Piece	2 5/8"	N/A	37 lb-ft	TQ-258-F37

Note: Turn Back Nut while holding Head fixed.

Connector Interface Torque Specifications				
Interface Type	Wrench size	Max Wrench Head Thickness	Torque Spec	Part Number
7-16 DIN male	1 1/4"	N/A	18 - 22 lb-ft	TQ-114-F18-M

F-Series Blade & Pilot Pin Replacement Instructions

for Cable Prep Tool: F-78, F-114, F-158

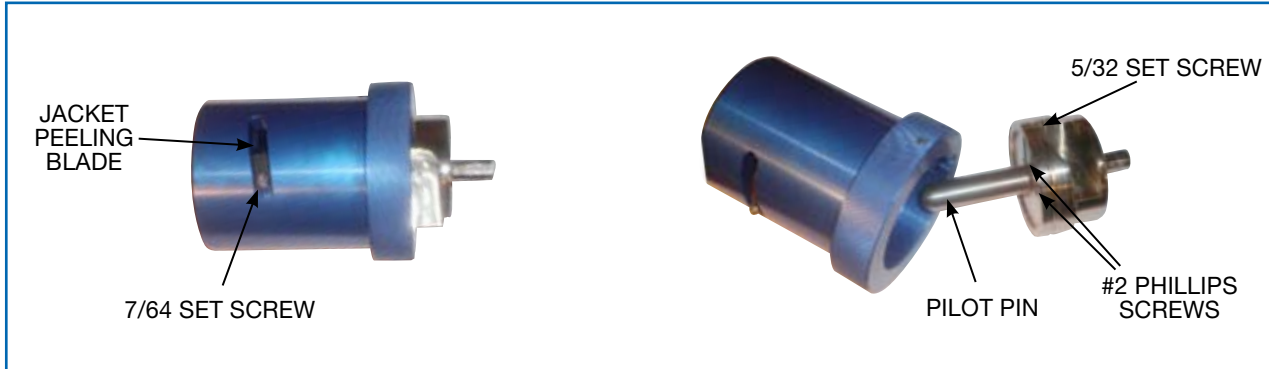

1. Using a 5/32 Allen wrench, loosen the set screw and remove the pilot pin.
2. Using a Phillips screwdriver, remove the two screws securing the trim tool blade.
3. Replace blade.
4. Using the two Phillips screws removed in step 2, secure the new blade in place.
5. Reinstall original or replacement pilot pin by pushing it in until it makes contact with the blade.
6. Secure the pilot pin by tightening the 5/32 set screw.

Replacement Part #s

	F-78	F-114	F-158
Trim Head Blade	SPB14	SPB14	SPB11
Pilot Pin	SPB03PP	SPB05PP	SPB01PP
Jacket Peeling Blade	SPB09	SPB09	SPB12



EUPEN Cable Inc.

5181 110th Avenue North, Unit D
Clearwater, FL 33760

800.419.5100 • fax: 727.528.0751

www.eupen.us

TAMPA BAY, FL • DALLAS, TX • SALEM, OR • PHILLIPSBURG, NJ • TORONTO • EDMONTON
MEXICO CITY • GUATEMALA CITY • BOGOTA